

1100 RETAIL LINEAR IMAGING SCANNER

Powerful
Innovative
Innovative



Auto-Stand



Desk Stand



Wall Stand

- Ergonomic and Light Weight
- Small Size (150mm)
- Reading Distance: from 2 cm up to 28 cm
- Ideal for Retail Applications

1100 RETAIL LINEAR IMAGING SCANNER

Specifications

Electrical

Voltage	+5V +/- 10%
Power Consumption	
Operation	150 mA
Standby	20 mA

Environmental

Temperature	0°~50°C (operating) -20°~60°C (storage)
Humidity	10%~90% non-condensing (operating) 0%~95% non-condensing (storage)
Shock Resistance	Withstand multiple drops from 2.0m onto a concrete surface

Physical

Weight	165g
Housing	ABS and Rubber
Switch	Micro switch
Color	2 Tone Light Grey/Dark Grey
Dimensions	91 x 73 x 146mm (L x W x H)

Optical

Light Source	Red LED (630nm)
Resolution	Up to 0.125mm (5mil)
PCS (Min.)	0.45
Scanning Engine	100 scans/sec
Ambient Light Rejection	Maximum 2000 lux fluorescent light or 1000 lux sun light

Safety & Regulatory Approvals

FCC class-A, CE-C-tick

Warranty

1 Year

Features

Keyboard Auto-detection	Built-in keyboard emulator for laptop (phony keyboard included)
CPU	16-bit CMOS, low power consumption
Interface Type	K-B Wedge, RS232, Wand Emulation, USB
Symbology Supported	Code 39/Full ASCII, Codabar, Pharma Code, Industrial 2 of 5, Interleave 2 of 5, Matrix 2 of 5, Code 93, Code 128, EAN 128, MSI, EAN 8&13, UPCA & E, Plessey
Keyboard Interface	IBM PC/XT/AT & compatible, PS2-30, PS-55
Indicator Buzzer	Programmable Tone
LED	Red Color for Good Read; Green Color for Status
Programmable Features	Autosense Mode Code ID, Prefix code, Postfix Code, Length Code, Barcode type, Buzzer frequency, ISBN/ISSN/CLSI/UK Plessey conversion, Keyboard layout, Inter-character delay, Scanning mode, Language type, Time out, Baud rate, Data bit, Transmission mode, Character replacement
Data Editing Mode	Three editing formats are supported. The following conditions can be programmed: code type, data length and location. Data can be divided into 6 Matching string fields. Five additional fields can be programmed for each editing format. User programmable field transmission sequence.
Language Support	English(US), English(UK), French, Italian, Belgian, Norwegian/Swedish, Spanish, Portuguese, German

Dimensions

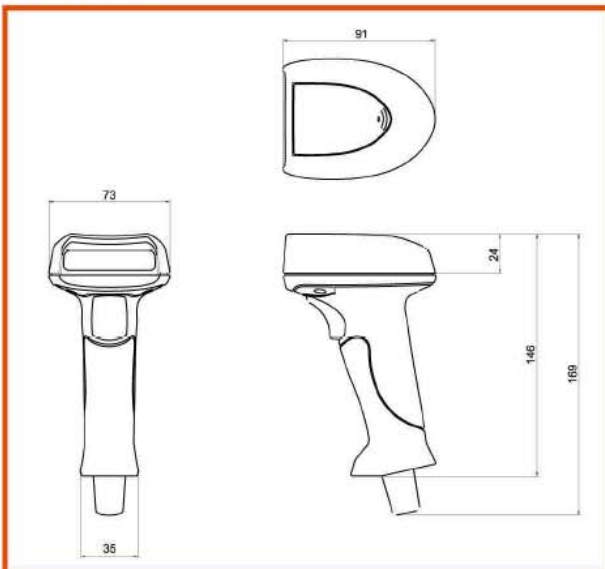

Reading Performance

